

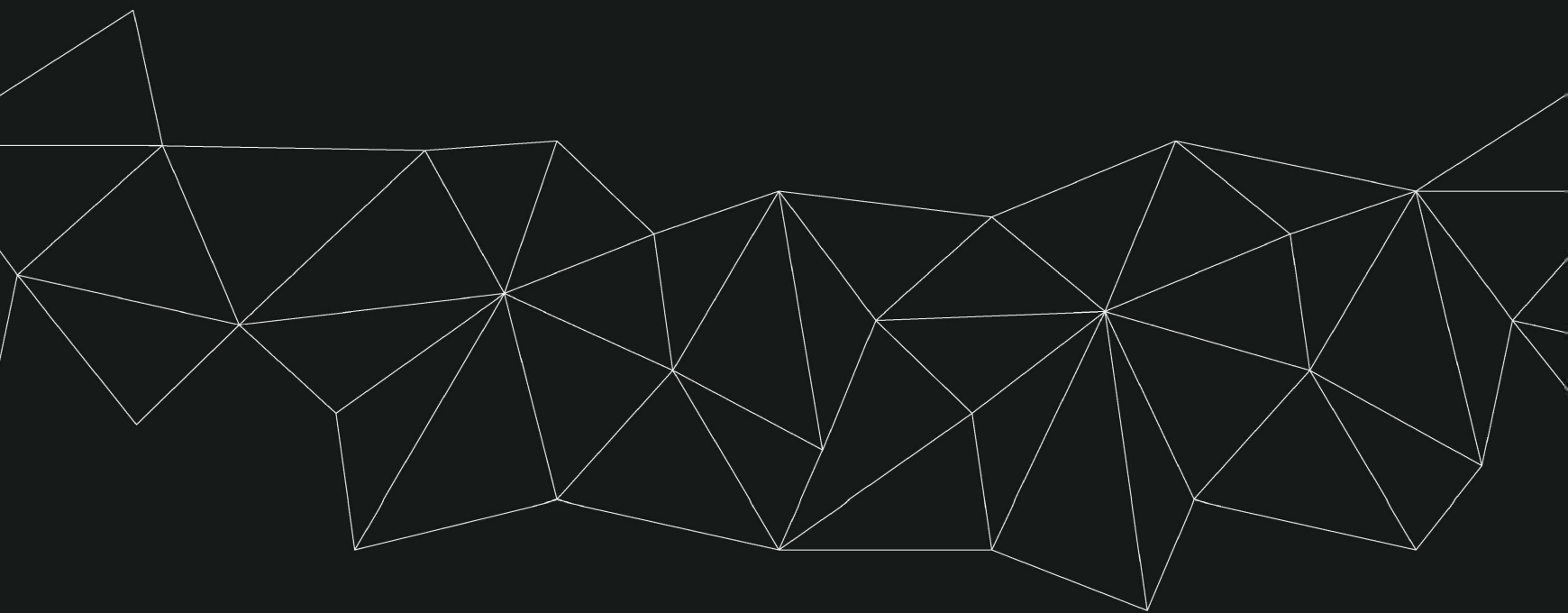

rauman
by eibho



SO.1



office

www.rauman.com

EXP
+PRC
+COM

EXP= Experiencia | Experience | Expérience
PRC= Producto | Product | Produit
COM= Conocimiento | Knowledge | Connaissance



En rauman queremos que nuestros clientes realicen sus proyectos Office con eficiencia, seguridad y confianza. Nuestra propuesta de valor es dedicarnos a eso que hacemos mejor: apoyarles a través de nuestro equipo, experiencia y conocimiento.

At rauman we want our clients to carry out their Office projects with efficiency, security and confidence. Our value proposition is to dedicate ourselves to what we do best: support them through our team, experience and knowledge.

Chez rauman, nous voulons que nos clients réalisent leurs projets Office avec efficacité, sécurité et confiance. Notre proposition de valeur est de nous consacrer à ce que nous faisons le mieux : les soutenir grâce à notre équipe, notre expérience et nos connaissances.

www.rauman.com

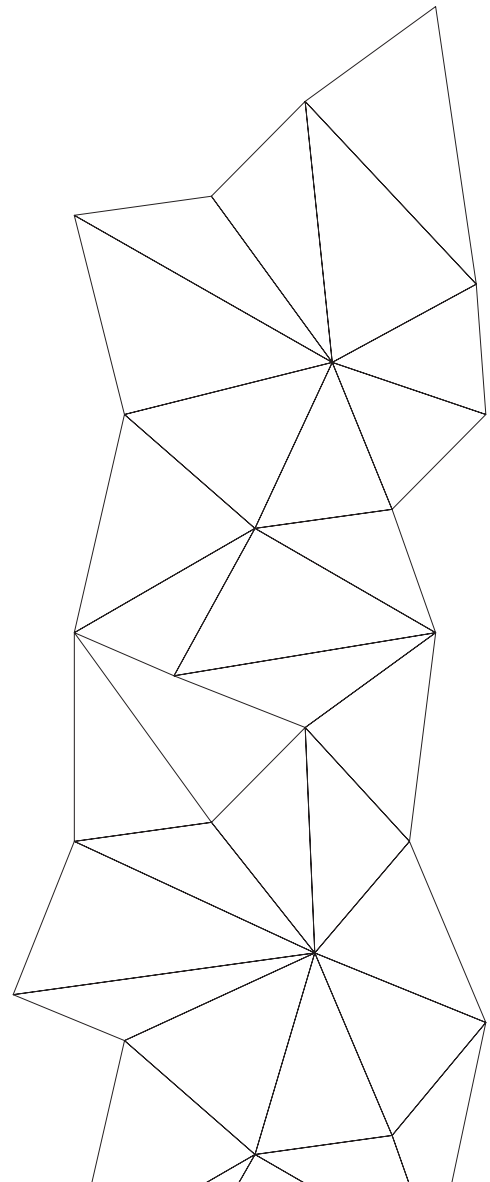



 **OFFICE**
SOLUTIONS



Mamparas de oficina |
Office partition Systems |
Systèmes de cloisonnement de bureaux.



El sistema S0.1, desarrollado por Rauman, es el resultado del feedback de nuestros colaboradores sobre una demanda específica del mercado. Un sistema de mampara basada en aluminio, de líneas sencillas y con certificación acústica y de seguridad estructural.

Rauman es el fabricante líder de sistemas de mamparas de oficina en España con 3 décadas de experiencia. Forma parte de Eibho Architectural Solutions.

The S0.1 system, developed by Rauman, is the result of the feedback provided by our collaborators regarding a specific demand of the market. A product line based on simple style aluminium, offering acoustic and structural safety certification.

Rauman is the leading office partition manufacturer in Spain with 3 decades of experience. It belongs to Eibho Architectural Solutions.

Le système S0.1, développé par Rauman, est le fruit du feedback de nos partenaires concernant une demande spécifique du marché. Un système de cloisons à base d'aluminium, aux lignes simples et certification acoustique et de sécurité structurelle.

Rauman est le fabricant leader de systèmes de cloisons de bureau en Espagne avec 3 décennies d'expérience. Il fait partie d'Eibho Architectural Solutions.



S0.1 | E40

34dB Rw Aislamiento acústico testado en laboratorio | Lab tested sound insulation | Isolation phonique testée en laboratoire

Seguridad estructural H 4000mm

Structural safety H 4000mm

Securité structurelle H 4000mm

SIMPLICIDAD Y TRANSPARENCIA



S0.1

SECCIONES SECTIONS

Techo
Top track
Plafond

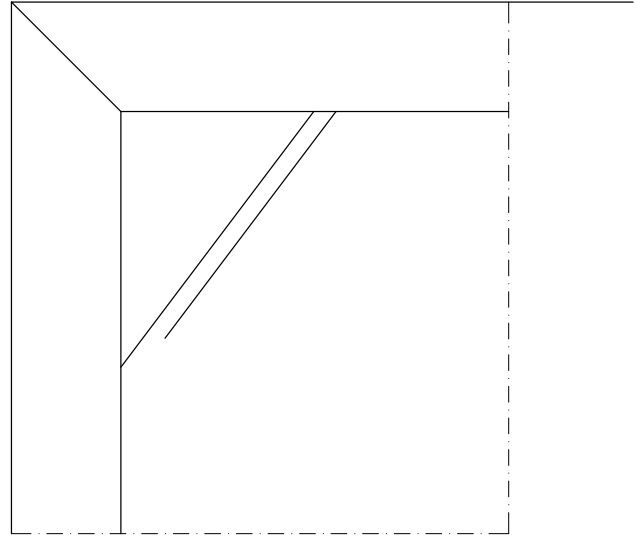
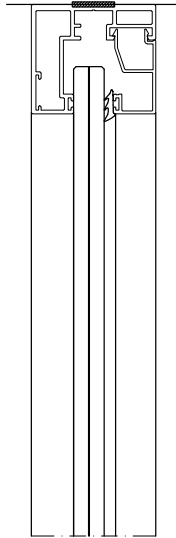

Suelo
Floor track
Sol

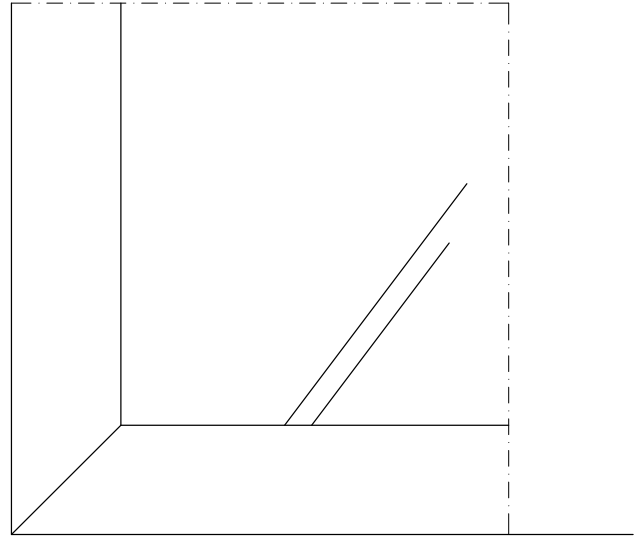
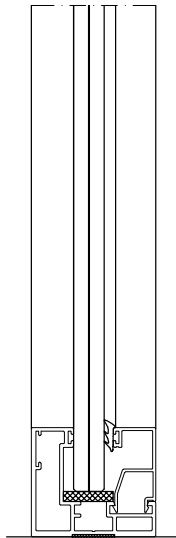

Pared
Wall track
Mur

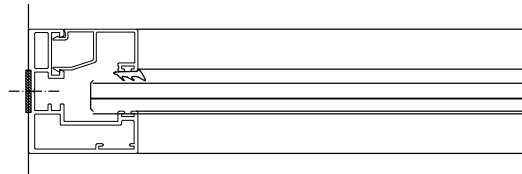

Simplicidad y pureza: mismos perfiles para techo, pared y suelo.
Simplicity and purity: same profiles for top, wall and floor tracks.
Simplicité et pureté: même profils pour plafond, mur et sol.



ENCUENTROS
CONNECTIONS
JONCTIONS

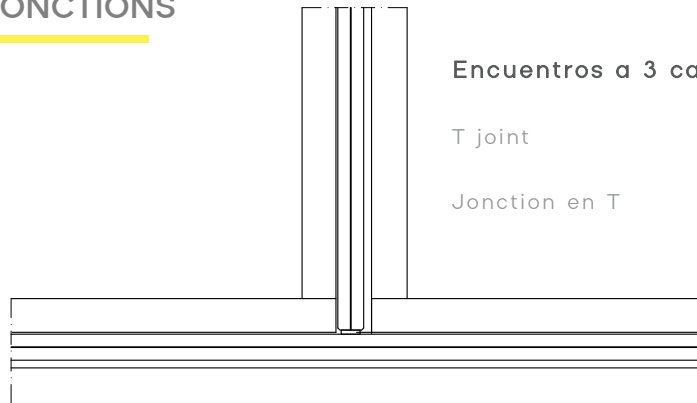

Encuentros a 3 caras

T joint

Jonction en T

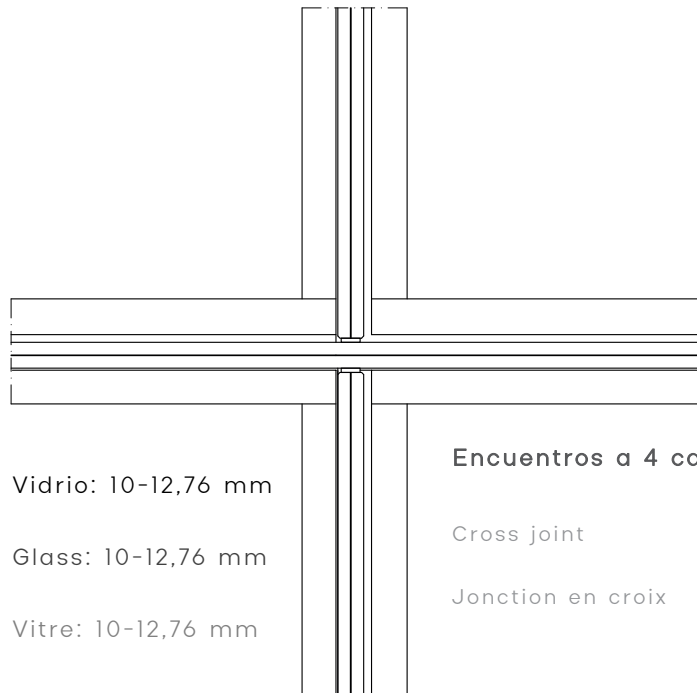

Vidrio: 10-12,76 mm

Glass: 10-12,76 mm

Vitre: 10-12,76 mm

Encuentros a 4 caras

Cross joint

Jonction en croix



**Encuentros a 90°
vidrio contra vidrio**

90° corner glass

Jonction à 90°



**Encuentros a 90°
con cantonera de aluminio**

90° corner glass

with aluminium profile

Jonction à 90° avec cornière
d'aluminium

MÓDULO DE ELECTRIFICACIÓN
TECHNICAL MODULE
MODULE D'ÉLECTRIFICATION

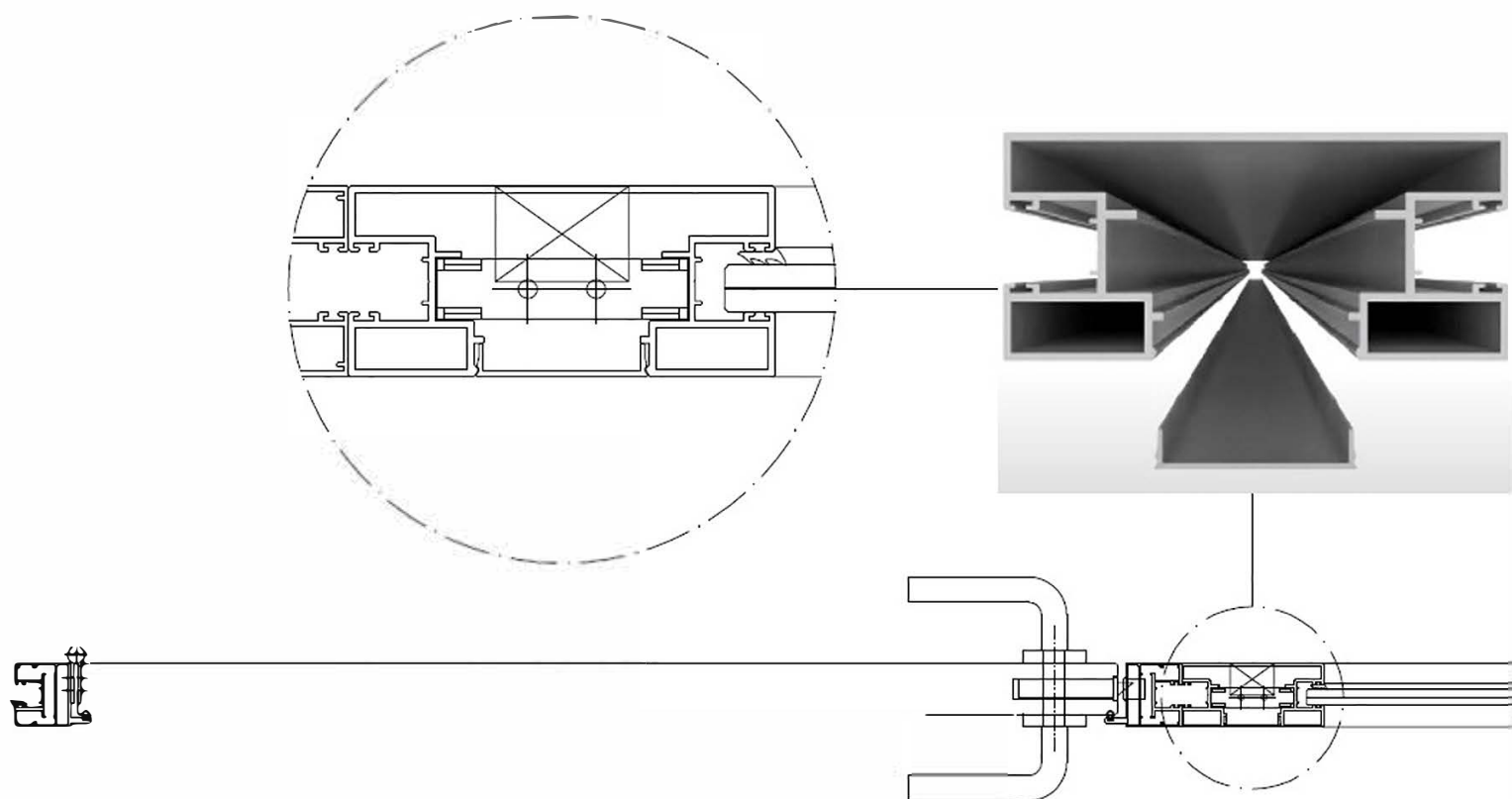

MÓDULOS DE PUERTA HOJA

SIMPLE SINGLE LEAF DOORS

PORTES SIMPLES



Puerta de vidrio sencilla securizada de 10 mm

10 mm-thick single-leaf securized glass door
Porte simple en verre sécurisée de 10 mm

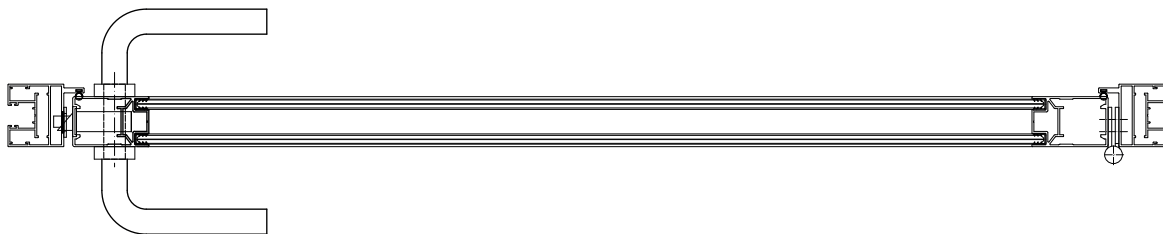

Puerta simple de doble vidrio enmarcada de 40 mm.

40mm.-thick single-leaf framed double glass
Porte simple double vitrage encadrée de 40 mm.

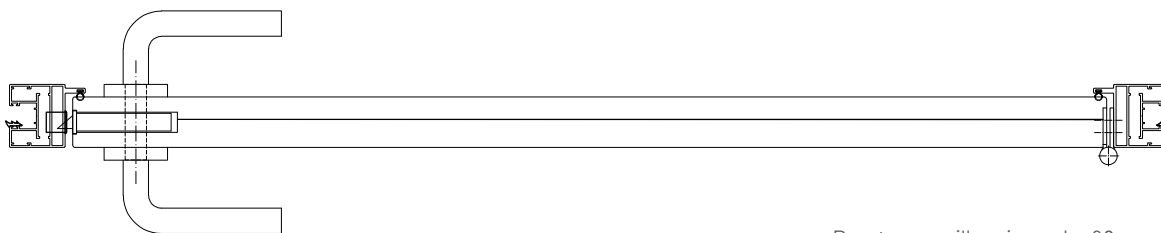

Puerta sencilla ciega de 38 mm

38 mm-thick single-leaf solid door
Porte pleine 38 mm

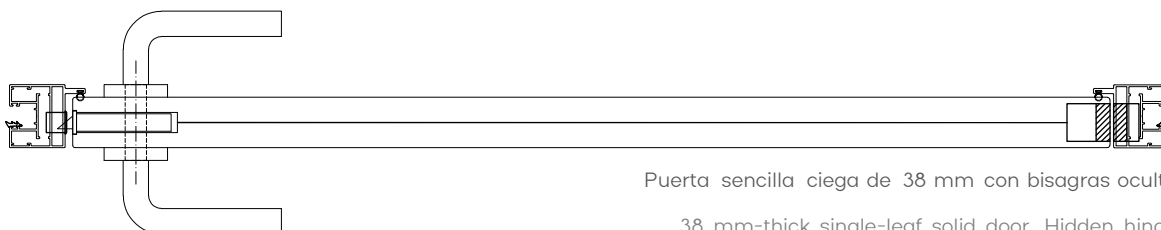

Puerta sencilla ciega de 38 mm con bisagras ocultas

38 mm-thick single-leaf solid door. Hidden hinges
Porte pleine 38 mm. avec charnière invisible

MÓDULOS DE PUERTA DOBLE HOJA

DOUBLE LEAF DOORS

PORTES DOUBLES

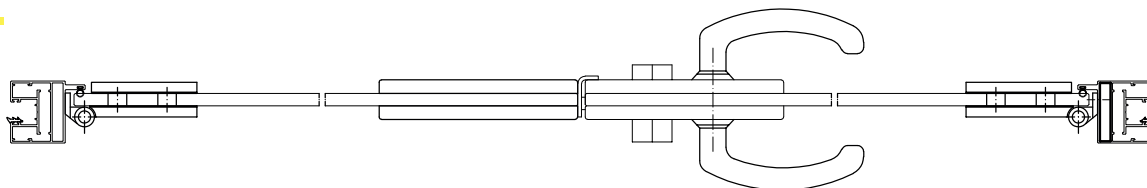

Puerta doble de vidrio securizada de 10 mm

10 mm-thick double-leaf securized glass door
Porte double en verre sécurisée de 10 mm

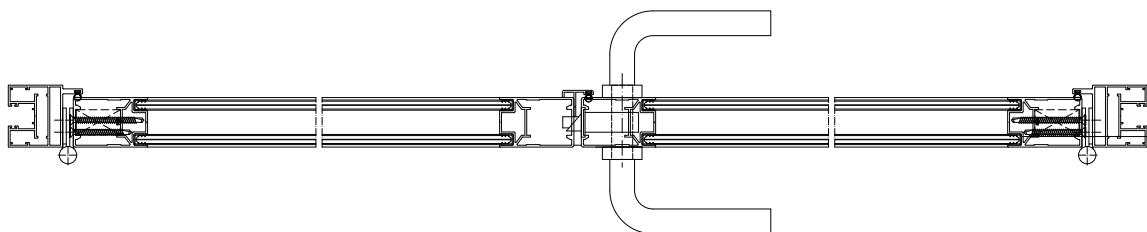

Puerta doble vidrio enmarcada de 40 mm.

40mm.-thick double-leaf framed double glass
Porte double vitrage encadrée de 40 mm.

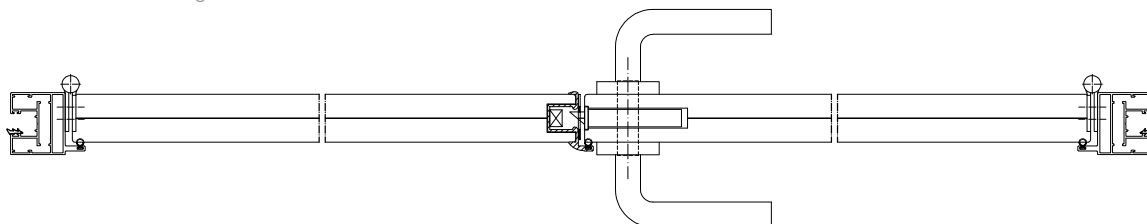

Puerta doble ciega de 38 mm

38 mm-thick double-leaf solid door
Porte double 38 mm

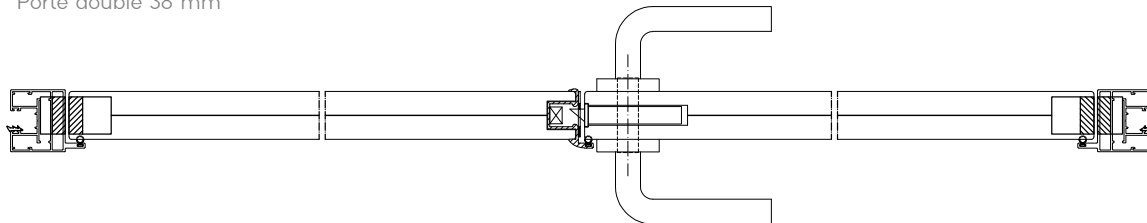

Puerta doble ciega de 38 mm con bisagras ocultas

38 mm-thick double-leaf solid door. Hidden hinges
Porte double 38 mm. avec charnière invisible

CÁLCULO DE LAS DIMENSIONES DE LOS VIDRIOS

GLASS PANE SIZE CALCULATION

CALCUL DES DIMENSIONS DES VITRES

Seguridad estructural hasta 4000mm

Structural safety up to 4000mm

Sécurité structurelle jusqu'à 4000mm

Nivelación de vidrios: +/-9mm por metro.

Glass levelling: +/-9mm per metre.

Nivellement des vitres: +/-9mm par mètre.

Absorción de altura: -19mm. +17mm.

Height absorption: -19mm. +17mm.

Absorption en hauteur: -19mm. +17mm.

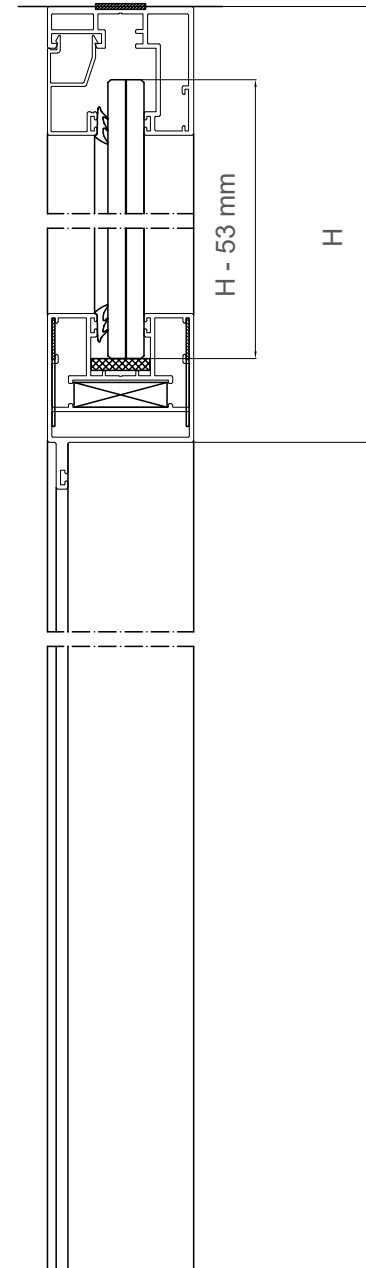
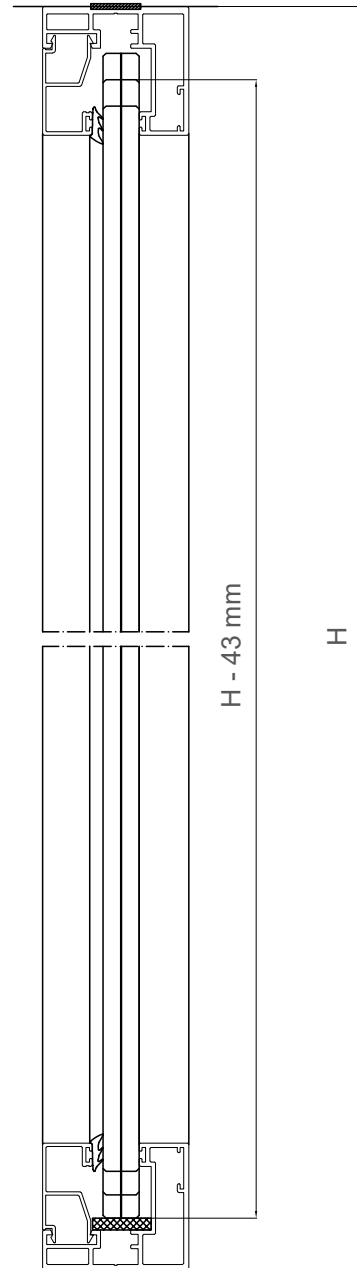

VIDRIO SUPERIOR PARA MÓDULO DE PUERTA, NO TECHO
UPPER GLASS FOR DOOR MODULE
VITRE SUPÉRIEUR POUR LE MODULE DE PORTE

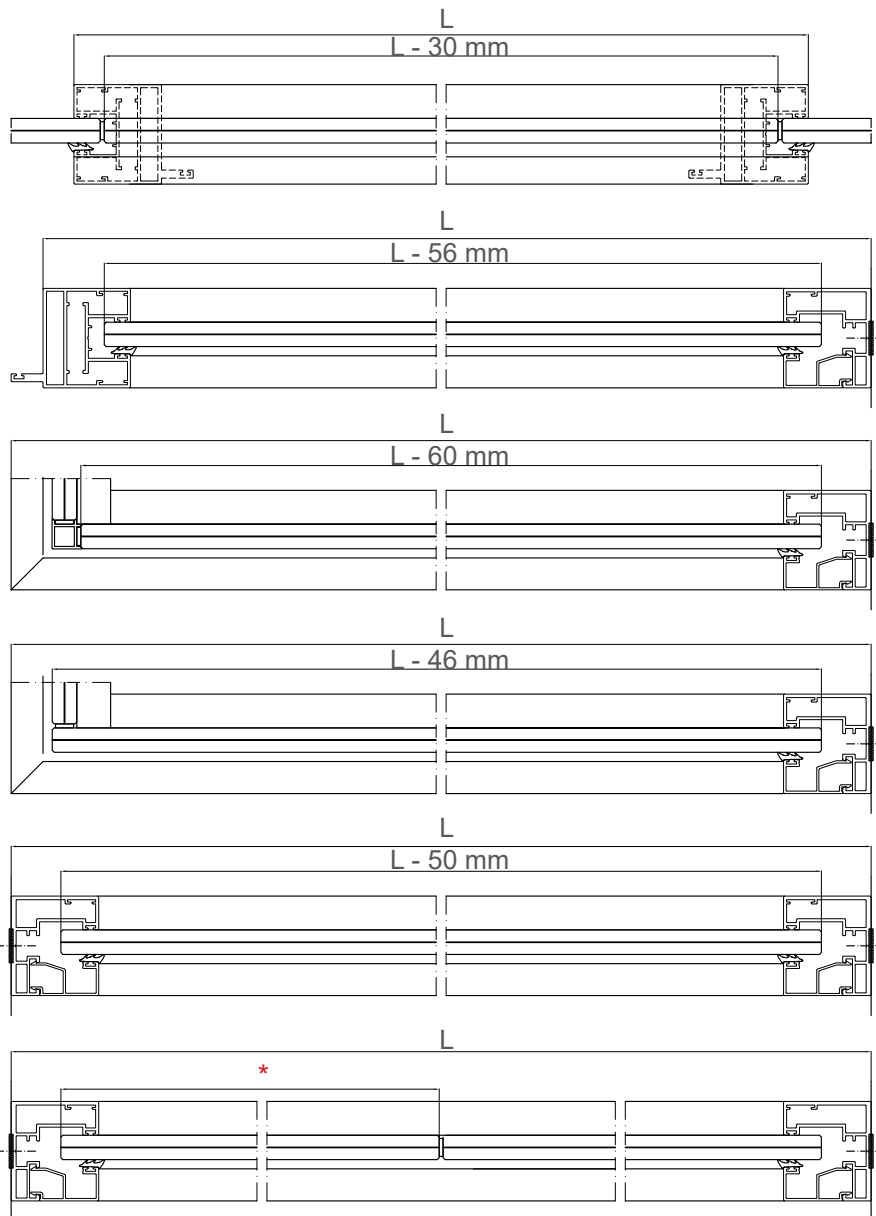

* $L - 50 - 2x$ (n° unión vertical entre vidrios)(n° de vidrios)

$L - 50 - 2x$ (number of vertical glass joints)(number of glass panes)

$L - 50 - 2x$ (n° de joints)(n° de vitres)





Acabados & calidad
Finitions & quality
Finitions & qualité

P. 18-25

ACABADOS & CALIDAD
FINISHES & QUALITY
FINITIONS & QUALITÉ



Acabados & calidad
Finitions & quality
Finitions & qualité

ES

Melaminados

Para otros acabados, consúltenos. Los colores y texturas de los acabados pueden variar vistos en pantalla. Solicítenos muestras para ver los colores exactos.

FR

Panneaux Mèlaminés

Contactez-nous pour différentes finitions. Les couleurs et les textures peuvent varier sur l'écran. Des échantillons sont à disposition des clients pour avoir les couleurs exactes.

EN

Melamine Panels

For different finishes, kindly contact us. The colours and textures may vary when seen on screen. Ask us for samples to have the exact colours.

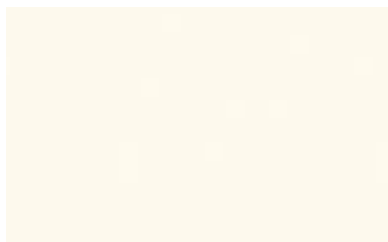

BLANCO KAOLIN W980 ST2
KAOLIN WHITE W980 ST2
BLANC KAOLIN W980 ST2



GRIS PERLA U763 ST9
PEARL GREY U763 ST9
GRIS PERLE U763 ST9

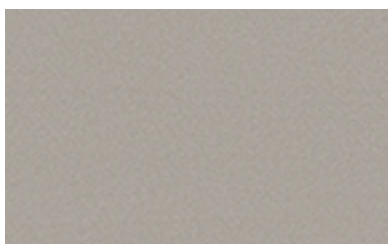

ALUMINIO F509 ST2
ALUMINIUM F509 ST2
ALUMINIUM F509 ST2



GRIS GRAFITO U961 ST2
GRIS GRAFITO U961 ST2
GRIS GRAFITO U961 ST2



ROBLE NEBRASKA NATURAL H3331 ST10
NEBRASKA OAK NATURAL H3331 ST10
CHÈNE NEBRASKA NATUREL H3331



ROBLE HAMILTON NATURAL H3303 ST10
HAMILTON OAK NATURAL H3303 ST10
CHÈNE HAMILTON NATUREL H3303 ST10



ROBLE BARDOLINO GRIS H1146 ST10
GREY BARDOLINO OAK H1146 ST10
CHÈNE BARDOLINO GRIS H1146 ST10



ROBLE NEBRASKA GRIS H3332 ST10
GREY NEBRASKA OAK H3332 ST10
CHÈNE NEBRASKA GRIS H3332 ST10



Acabados & calidad
Finitions & quality
Finitions & qualité

ES

Lacados

Para otros acabados, consúltenos. Los colores y texturas de los acabados pueden variar vistos en pantalla. Solicítenos muestras para ver los colores exactos.

FR

Lacquered

Contactez-nous pour différentes finitions. Les couleurs et les textures peuvent varier sur l'écran. Des échantillons sont à disposition des clients pour avoir les couleurs exactes.

EN

Finitions Laquées

For different finishes, kindly contact us. The colours and textures may vary when seen on screen. Ask us for samples to have the exact colours.



9010 BLANCO PURO
9010 PURE WHITE
9010 BLANC PUR

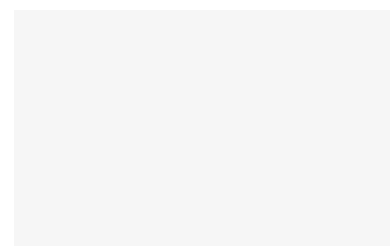

9010 BLANCO PURO IMAT
9010 PURE WHITE IMAT
9010 BLANC PUR IMAT

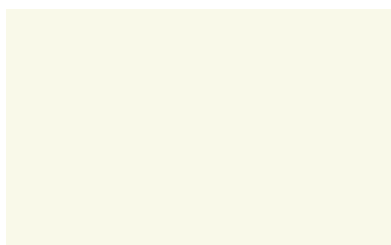

9010 BLANCO PURO ITXT
9010 PURE WHITE ITXT
9010 BLANC PUR ITXT

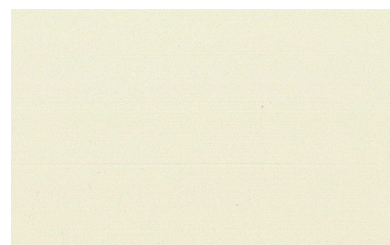

1013 BLANCO PERLA
1013 OYSTER WHITE
1013 BLANC PERLÉ

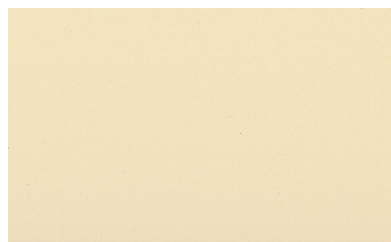

1015 MARFIL CLARO
1015 LIGHT IVORY
1015 IVORY CLAIR

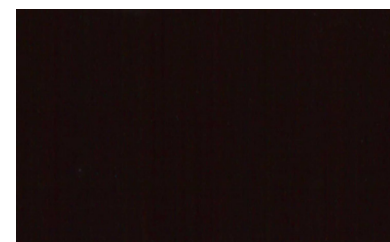

8017 CHOCOLATE
8017 CHOCOLATE BROWN
8017 BRUN CHOCOLAT



9011 NEGRO GRAFITO
9011 GRAPHITE BLACK
9011 NOIR GRAPHITE

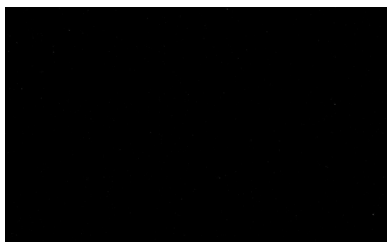

9011 NEGRO GRAFITO IMAT
9011 GRAPHITE BLACK IMAT
9011 NOIR GRAPHITE IMAT

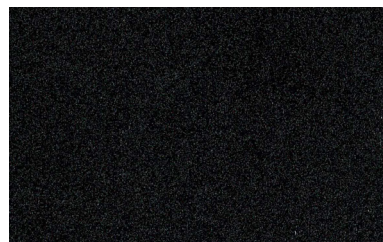

9011 NEGRO GRAFITO MATE ITXT
9011 GRAPHITE BLACK MATE ITXT
9011 NOIR GRAPHITE MATE ITXT

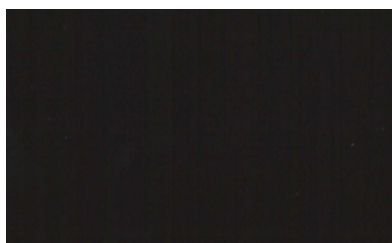

8019 PARDO GRISÁCEO
8019 GREY BROWN
8019 BRUN GRIS

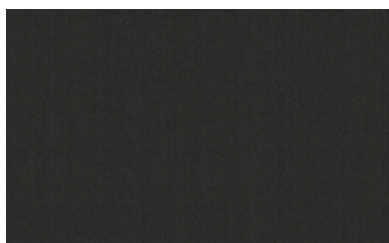

8019 PARDO GRISÁCEO IMAT
8019 GREY BROWN IMAT
8019 BRUN GRIS IMAT

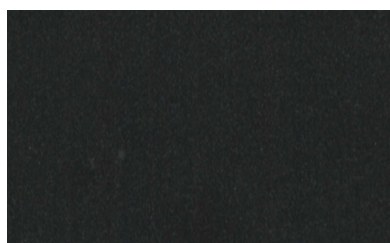

8019 PARDO GRISÁCEO ITXT
8019 GREY BROWN ITXT
8019 BRUN GRIS ITXT

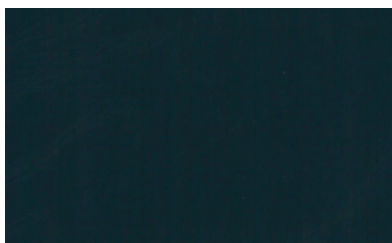

7016 GRIS ANTRACITA
7016 ANTHRACITE GREY
7016 GRIS ANTHRACITE



7016 GRIS ANTRACITA IMAT
7016 ANTHRACITE GREY IMAT
7016 GRIS ANTHRACITE IMAT

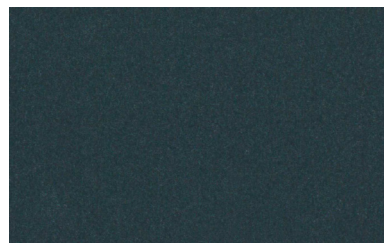

7016 GRIS ANTRACITA ITXT
7016 ANTHRACITE GREY ITXT
7016 GRIS ANTHRACITE ITXT

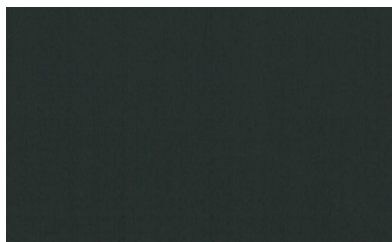

7022 GRIS SOMBRA
7022 UMBRA GREY
7022 GRIS TERRE D'OMB

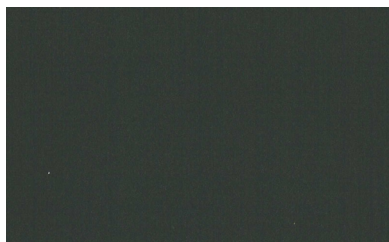

7022 GRIS SOMBRA IMAT
7022 UMBRA GREY IMAT
7022 GRIS TERRE D'OMB IMAT



7022 GRIS SOMBRA ITXT
7022 UMBRA GREY ITXT
7022 GRIS TERRE D'OMB ITXT



Acabados & calidad
Finitions & quality
Finitions & qualité

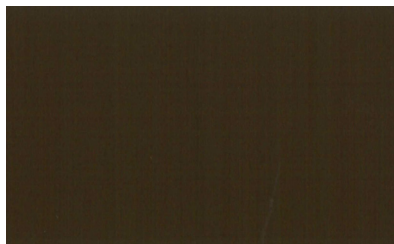

8014 SEPIA
8014 SEPIA BROWN
8014 BRUN SÉPIA



5013 AZUL COBALTO
5013 COBALT BLUE
5013 BLEU COBALT



3007 ROJO NEGRUZCO
3007 BLACK RED
3007 ROUGE NOIR

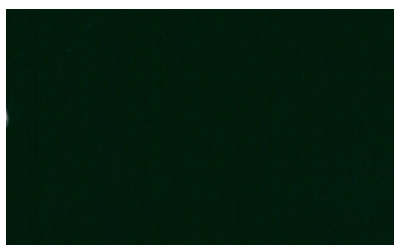

6009 VERDE ABETO
6009 FIR GREEN
6009 VERT SAPIN



6005 VERDE MUSGO
6005 MOSS GREEN
6005 VERT MOUSSE

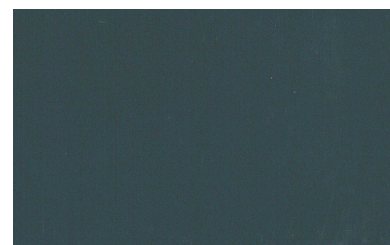

7012 GRIS BASALTO
7012 BASALT GREY
7012 GRIS BASALTE



3004 ROJO PÚRPURA
3004 PURPLE RED
3004 ROUGE POURPRE

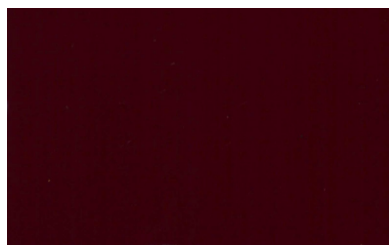

3005 ROJO VINO
3005 WINE RED
3005 ROUGE VIN

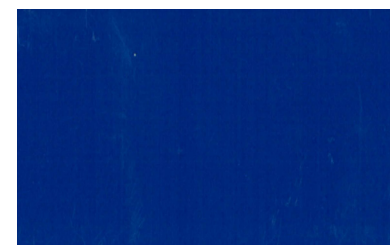

5010 AZUL GENCIANA
5010 GENTIAN BLUE
5010 BLEU GENTIANE

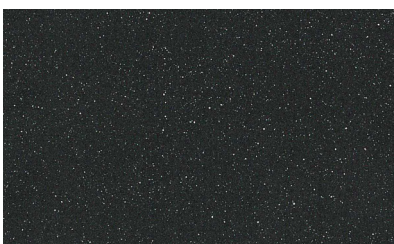

G-GRAFITO
G-GRAPHITE
G-GRAPHITE

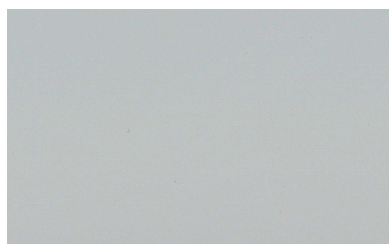

7035 GRIS CLARO
7035 LIGHT GREY
7035 GRIS CLAIR



9006 ALUMINIO BLANCO
9006 WHITE ALUMINIUM
9006 ALUMINIUN BLANC



colofull offices



Acabados & calidad
Finitions & quality
Finitions & qualité

ES

Anodizados

Para otros acabados, consúltenos. Los colores y texturas de los acabados pueden variar vistos en pantalla. Solicítenos muestras para ver los colores exactos.

FR

Anodized

Contactez-nous pour différentes finitions. Les couleurs et les textures peuvent varier sur l'écran. Des échantillons sont à disposition des clients pour avoir les couleurs exactes.

EN

Finitions Anodisées

For different finishes, kindly contact us. The colours and textures may vary when seen on screen. Ask us for samples to have the exact colours.

Acabado estándar en stock.
Resto de acabados consultar.

tandard finish in stock. For other
finishes, contact us.

Finition standard en stock. Pour d'autres
finitions, veuillez nous consulter.

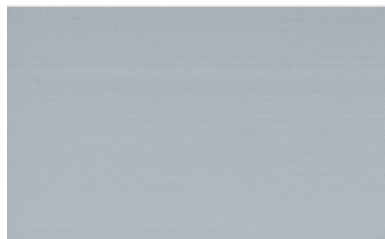

PLATA MATE
MATTE SILVER
ARGENT MAT



PLATA GRATA
SILVER ROUGH BRUSHED
ARGENT GRATÉ



INOX MATE
MATTE INOX
INOX MAT



INOX GRATA
ROUGH BRUSHED INOX
INOX GRATÉ



NEGRO MATE
MATTE BLACK
NOIR MAT



NEGRO GRATA
BLACK BRUSHED
NOIR GRATÉ



BURDEOS MATE
MATTE BOURDEAUX
BOURDEAUX MAT



BURDEOS GRATA
BOURDEAUX BRUSHED
BOURDEAUX GRATÉ



BRONCE GRATA
BRUSHED BRONZE
BRONZE GRATÉ

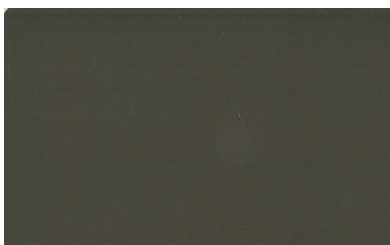

BRONCE MATE
MATTE BRONZE
BROZE MAT



ORO GRATA
GOLD BRUSHED
OR GRATÉ



GRATA REPULIDO
ROUGH BRUSHED AND RE-POLISHED
GRATÉ REPOLÍ

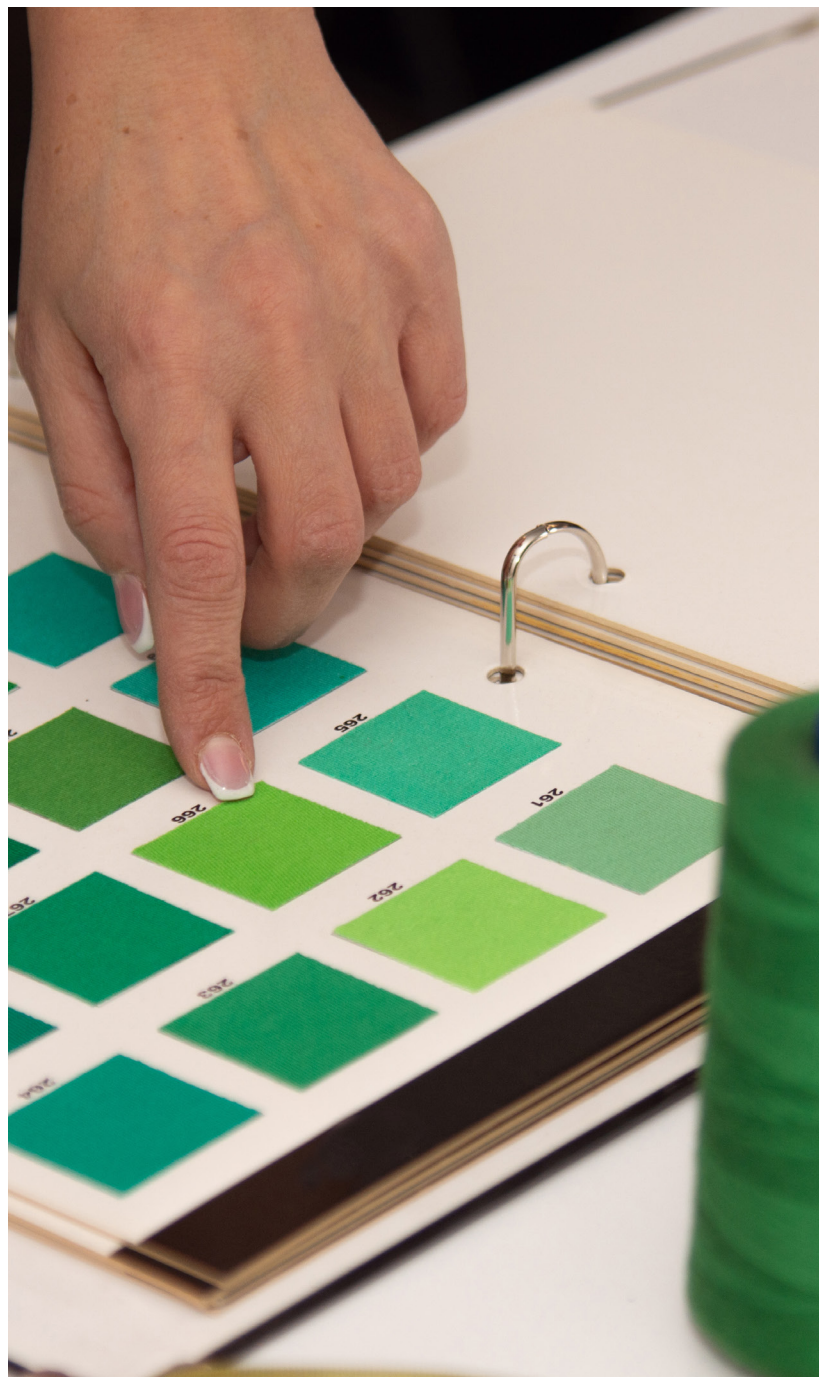

Acabados & calidad
Finitions & quality
Finitions & qualité



Sede Central
Headquarters
Siège Social

Bizkaia

Pol. Ind. Solozabal
Avda. Euskal Herria, s/n
48250 Zaldibar (Bizkaia)
Tel: (+34) 946 23 61 10
info@rauman.com

Sucursales
Branches
Branches

Bizkaia

Pol. Ind. Lezama-Leguizamón
C/ Bizkaia, 24
48450 Etxebarri (Bizkaia)

Gipuzkoa

Asteasuko Industrialdea
Sector A, 27
20159 Asteasu (Gipuzkoa)

Álava

Pol. Ind. Ali-Mercedes
C/ Düsseldorf, 5 / Pab. 12-14
01010 Vitoria (Álava)

Cantabria

Pol. Ind. Guarnizo
Parc. 224
39611 Astillero (Cantabria)

La Rioja / Navarra

Pol. Ind. Puente Madre
C/ María Teresa León, 4
26142 Villamediana de Iregua
(La Rioja)

Asturias

Pol. Ind. La Peñona
C/ La Mecánica, 329
33691 Gijón (Asturias)

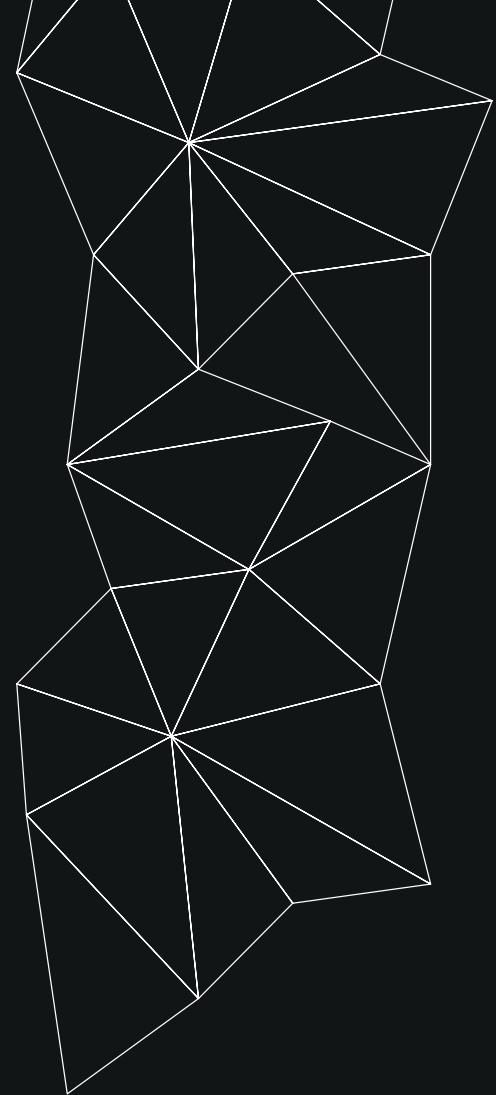

www.rauman.com



Declaración ambiental de producto.
75% de la producción con aluminio reciclado.

Environmental product declaration.
75% of production with recycled aluminium.

Déclaration environnementale du produit.
75% de la production avec de l'aluminium recyclé.

Descubre todos nuestros servicios
y productos en nuestra web.

Discover all our services
and products on our website.

Découvrez tous nos services
et produits sur notre site internet.

